

Contents

Symbols, safety	2
General safety information	2
Correct use	3
Improper use	3
Operating parameters	4
Preparation	5
Installation	5
Installing the guide carriage	6
Potential applications	7
Timing-Belt Reverse Unit 5 40 R10 with Bore	8
Potential applications	8
Installing the Timing Belt	8
Securing and tensioning Timing Belt R10 T5	9
Accessories	10
Connecting Drive Set 5 40 D30/D12 - 0.0.662.49	11
Connecting Drive Set ZU 5 40 D30/D12 AP/WP 40 - 0.0.672.74	12
Synchronising Linear Unit LRE 5 D6 60x20 ZU 40 R10	14
Lubrication	15
Maintenance	15

Symbols, safety



Meaning:
Important, safety information, recommendation



Maintenance

General safety information

The details and information in the installation guide are provided solely for the purposes of describing the product and the assembly of this particular variant – Linear Unit LRE 5 D6 60x20 ZU 40 R10. The text below usually refers to this as the Linear Unit or LRE. This information does not discharge the user from the obligation to carry out his own assessments and checks. It is important to bear in mind that our products are subject to a natural process of wear and ageing. These notes contain important information that will enable you to use the product safely and appropriately. When sold, rented out or otherwise passed on to another party, this product must be handed over with the installation guide.

When installing, disassembling, operating and maintaining the Linear Unit, it is important to ensure that all moving elements are secured so that they cannot be switched on and moved unintentionally. Rotating and moving parts can cause serious injury! You must therefore read and follow the safety instructions set out below.

- All work on and with the Linear Unit must be performed with “safety first” in mind.
- Always switch off the drive unit before you start working on the Linear Unit.
- Ensure the drive unit is not switched on unintentionally, e.g. by affixing warning notices at the activation point or by removing the fuse from the power supply.
- Do not place your hand within the operating range of the Linear Unit’s moving parts when the unit is still switched on.
- Fit guards and covers to the moving parts of the Linear Unit to ensure they are not touched unintentionally.

- Observe the regulations pertaining to accident prevention and environmental protection that apply in the country and place of work where the product is being used.
- Use only products that are in perfect working order.
- Failure to use original spare parts will invalidate the product warranty!
- Check the product for obvious defects.
- Use the product only within the performance range described in the technical data.
- Ensure that all the safety equipment associated with the product is present, properly installed and in full working order.
- Do not alter or circumvent safety equipment, or render it ineffective.

The Linear Unit described here corresponds to the state of the art and takes into account the general principles of safety applicable at the time this installation guide was published. Nevertheless, failure to observe the safety instructions and warning notices in this installation guide may result in personal injury and damage to property.

We will assume no liability for any resulting damage or injury. We reserve the right to make technical changes that represent technical advances. Keep these installation notes in a place where they can be easily accessed by all users. Observe the directions contained in the main user guide for the completed machine.

The general safety information applies to the entire lifecycle of the partly completed machine.

1. During transportation

Observe the handling instructions on the packaging. Until it is installed, the product must be stored in its original packaging, protected from moisture and damage. Ensure that moving parts are secured when in transit and cannot cause any damage.

2. During installation

Always deactivate the power to the relevant system part and ensure it is not live before installing the product and/or plugging it in or unplugging it. Ensure the system cannot be switched back on. Lay cables and lines in such a way that they cannot be damaged and do not represent a trip hazard. Avoid areas that pose slip, trip and fall hazards.

3. During commissioning

Allow the product to acclimatise for a few hours before starting to use it. Ensure that the partly completed machine is securely and safely integrated into the completed machine. Only start up a product that has been installed in full.

4. During operation

Ensure that only persons who have been authorised by the operator have access to the immediate operating area of the system. This also applies when the system is not in operation. It must not be possible to actuate moving parts unintentionally. In the event of an emergency, malfunction or other irregularity, deactivate the system and ensure it cannot be switched back on. Prevent the possibility of persons becoming trapped in the system's accessible hazard zone.

5. During cleaning

Close all openings with suitable protective equipment to ensure that cleaning agents cannot penetrate the system. Do not use aggressive cleaning substances. Do not use a high-pressure cleaner when cleaning the system.

6. During maintenance and servicing work

Carry out the prescribed maintenance work at the intervals stipulated in the user guide. Ensure that no line links, connections or components are removed while the system is live and under pressure. Ensure the system cannot be switched back on.

7. During disposal

Dispose of the product in accordance with the national and international regulations that apply in your country.

Correct use

Linear Unit LRE 5 D6 60x20 ZU 40 R10 with Controller and Motor is a partly completed machine as defined in the Machinery Directive (2006/42/EC). It must only be used in accordance with the technical data and safety requirements set out in this document. Internal company requirements and the regulations that apply in the country where the product is being used must be observed. You must not make any design modifications to the aforementioned Linear Unit yourself. We will assume no liability for any resulting damage or injury. You may only install, operate and maintain the Linear Unit if:

- The Linear Unit has been integrated properly and safely into the completed machine,
- You have carefully read and understood the installation guide,

- You are appropriately qualified,
- You are authorised to do so by your company,
- You are using only original equipment from the manufacturer.

Unsafe or inappropriate use of the Linear Unit runs a risk of serious injury through crushing and cuts.

Improper use

Improper use is defined as any use of the product for purposes other than those authorised in the installation guide and under the definition of correct use. We will assume no liability for any resulting damage or injury.

Operating parameters

Linear Unit LRE 5 D6 60x20 ZU 40 R10 is generally constructed from Line 8 profiles that have been cut to size and various assemblies. Before starting installation work, it is important to check that all parts are present.

The maximum possible drive torque is: $T_D = 3.3 \text{ Nm}$

The frictional torque or starting torque without load for the Linear Unit, depending on the Timing-Belt Reverse Units and Timing Belt tension, is: $T_F = 0.2 \text{ Nm}$

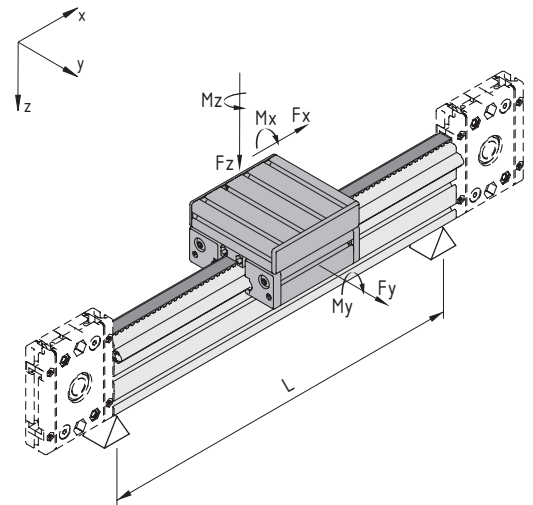

	Support width L_{max} when F_z max [mm]	Support width L_{max} when F_y max [mm]	F_y max [N]	F_z max [N]	M_x max [Nm]	M_y max [Nm]	M_z max [Nm]	Operating load F_x max [N]
Linear Unit LRE 5 D6 60x20 ZU 40 R10	1200	400	400	320	4	6	8	150

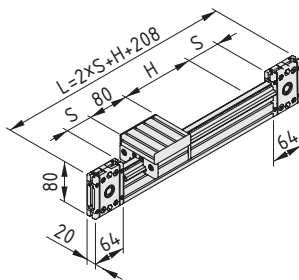

Linear Unit LRE 5 D6 60x20 ZU 40 R10

5

Maximum stroke H_{max}	2828	mm
Safety clearance S	46	mm
Basic mass (when stroke length = 0 mm) m_1	1.2	kg
Mass per mm of stroke m_2	1.9	g/mm
Total mass $m =$	$m_1 + H * m_2$	
Repeatability	0.15	mm
Maximum acceleration	10	m/s^2
Maximum travelling speed	5	m/s
Feed constant	140	mm/r

1 pce.

0.0.666.89

! The safety distance S is a reserve distance to accommodate tolerances and carriage overtravel under high loads and accelerations at the reversal point. It must be factored into the equation depending on the capabilities of the drive and Controller, but in any event should not be smaller than shown!

Environmental considerations:

Storage temperature: -20°C to $+70^\circ\text{C}$

Relative humidity: 5% to 85%

Linear Unit LRE is intended as a permanent fixture to be used in an area that is protected from the weather.

The area should be free from mould and fungus and show no traces of rodents or other pests.

Do not install or use in close proximity to industrial plants that produce chemical emissions.

Do not install or use near sources of sand or dust.

Do not install or use in an area that is regularly exposed to high-energy surges such as those caused by presses or heavy machinery, for example.

In case of doubt regarding resistance to certain chemicals such as test oil, alloyed oils, aggressive cleaning substances, solvents or brake fluid, we advise that you consult your specialist representative.

Consult the manufacturer if using in very salty air. Deflection in the linear axis of the LRE should not exceed 1 mm over an axis of 1000 mm. In scenarios where high demands are placed on the system dynamics, supports should be added every 300 mm to 600 mm. These supports must not affect the Reverse Units.

Preparation

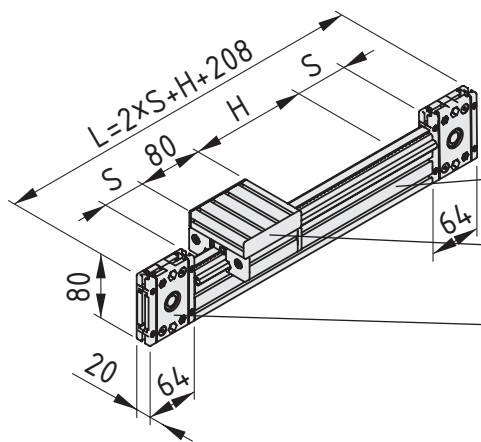

Support profile,
e.g.: Profile 5 60x20

Guide,
e.g.: Roller guide 5 D6

Drive,
e.g.: Timing Belt R10 T5 and Timing-Belt Reverse Unit 5 40 R10 with Bore

Fundamentally, a Linear Unit converts a rotary motion into a translational motion.

A Linear Unit is made up of:

- Guide
- Drive
- Support profile

These components are picked for assembly and assembled in part or in full, depending on customer wishes.

Installation

Shaft-Clamp Profile and Shaft:

There are various methods for assembling support profile, Shaft-Clamp Profile and Shaft.

To make installation easier, apply a film of oil or grease to the outer surfaces of the Shaft-Clamp Profile that come into contact with the support profile before pressing it into the groove. Do the same to the contact points between the Shaft and Shaft-Clamp Profile and to the guiding Shaft itself. When working with short support profiles that have not yet been connected to a fixture, it is advantageous to undertake installation in the following steps:

- Press the Shaft-Clamp Profile into the relevant groove of the support profile
- Use a vice (fitted with protective jaw plates) to press in the Shaft
- Follow the same sequence for the other side

On longer stretches, when the support profiles have already been installed or are being held in a vice and the Shaft-Clamp Profile has been pressed into place, you can press the shaft into the Shaft-Clamp Profile section by section using the Mounting Aid (0.0.265.38) and a lever in the form of a suitable round steel bar.

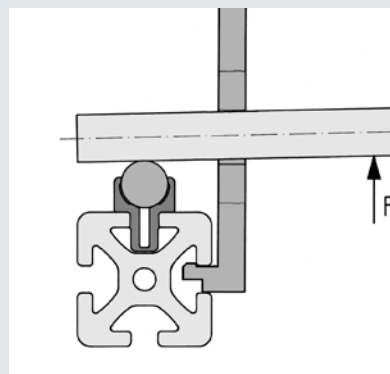

Installing the guide carriage

Once the support profile has been machined, prepared and connected with the Shaft-Clamp Profiles, the guide carriage can be slotted into place on it.

Slot the carriage on before fitting the End Cap and Lubricating System (or remove the latter first).

To build a linear guide, you need a centric (fixed) Double-Bearing Unit and a counterpart, eccentric (adjustable) Double-Bearing Unit.

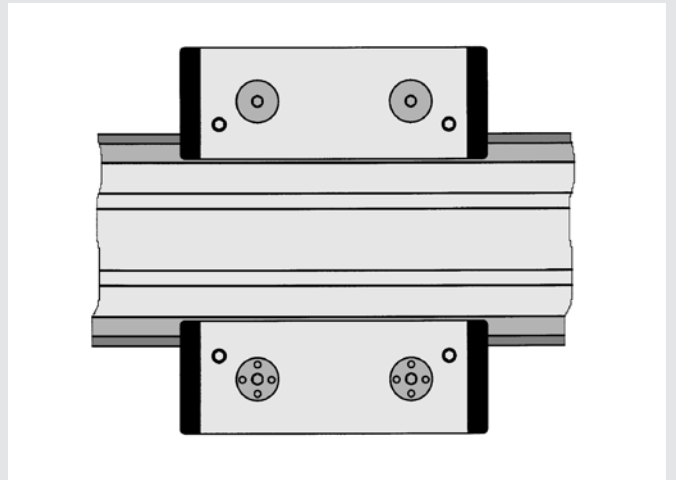

Double-Bearing Units 5 D6 offer a range of fastening options via Line 5 grooves, which makes it far easier to mount and align them on profiles and carriage plates. The heads of the Button-Head Screws and Washers are located within one of the grooves on the Bearing Unit, which means through holes need to be provided so that an Allen key can reach the screws. Holes for the most common fixing arrangement have been pre-drilled into the Bearing Units.

Tightening torque for Button-Head Screw ISO 7380 M5x8: 5 Nm

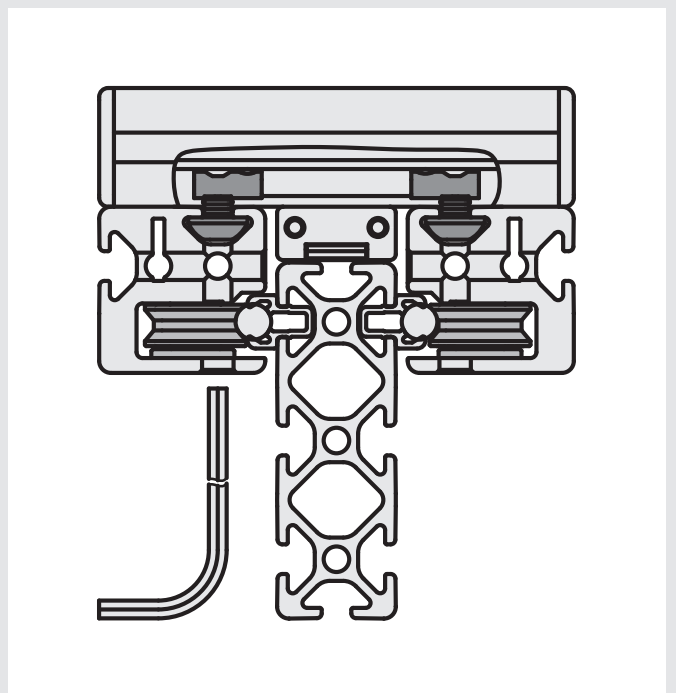

You must prepare the eccentric orientation of the eccentric Bearing Units before using the guide carriage.

Use an Allen key to turn the eccentric bolt of the rollers:

- Drive the bolt as far as it will go
- Turn back ½ a turn
- Continue turning back until the rearmost eccentric position is reached

When Bearing Units have been prepared and installed in this way, the maximum play between the rollers and Shafts can be used to adjust preload. When adjusting the Bearing Units to eliminate play, ensure that no excess strain is generated!

After making this adjustment, fix the position of the eccentric bolt by securing the lock nut with a Pin Spanner (T). While doing so, use an Allen key to hold the bolt in its selected position.

T = 3 Nm

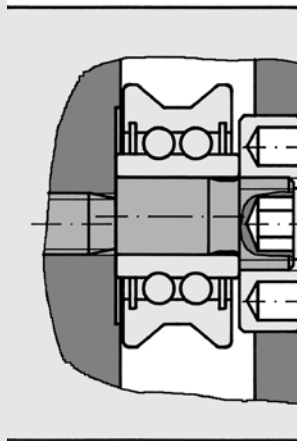

Fit the End Cap and Lubricating Systems once the carriage has been adjusted so that it is free from play.

Application options

In combination with Profile 5 60x20 as a support profile and a carriage from Line 5:

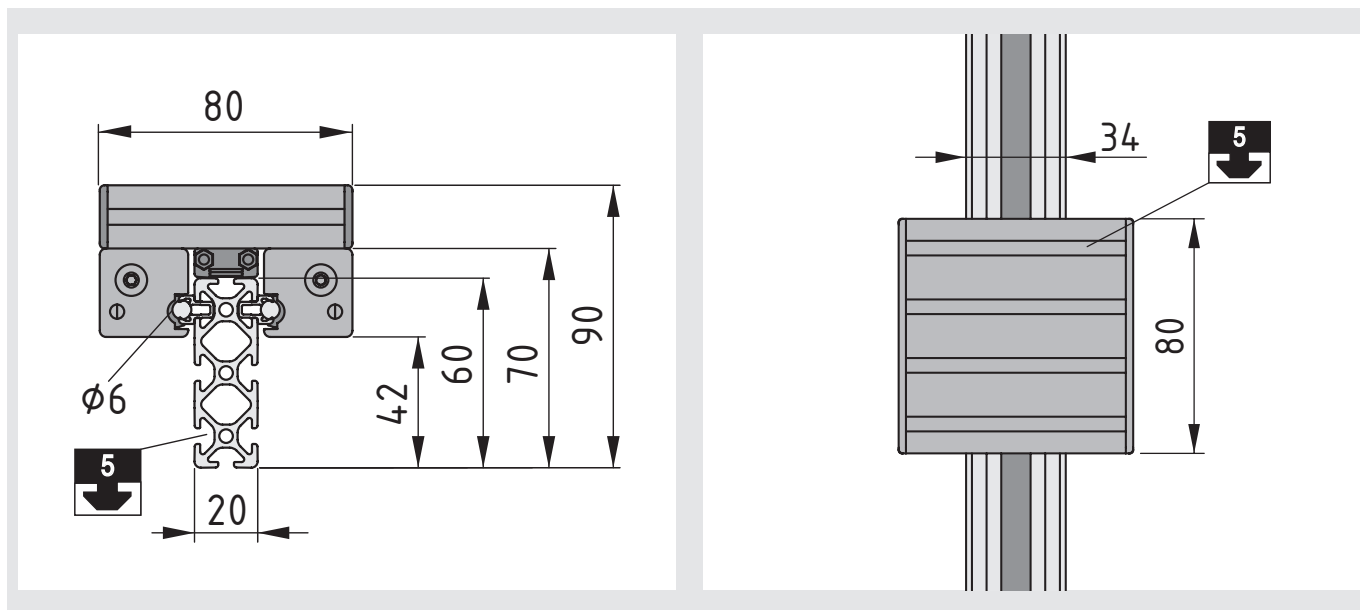

Timing-Belt Reverse Unit 5 40 R10 with Bore

Once the carriage has been fitted to the support profile and adjusted to eliminate play, the Timing-Belt Reverse Units can be prepared.

Timing-Belt Reverse Units 5 40 R10 with Bore for an expanding hub coupling are used to drive or reverse Timing Belt R10 T5 to build Linear Units combined with guides, Gearboxes and Drive Units.

Application options

In combination with Profile 5 60x20 as a support profile:

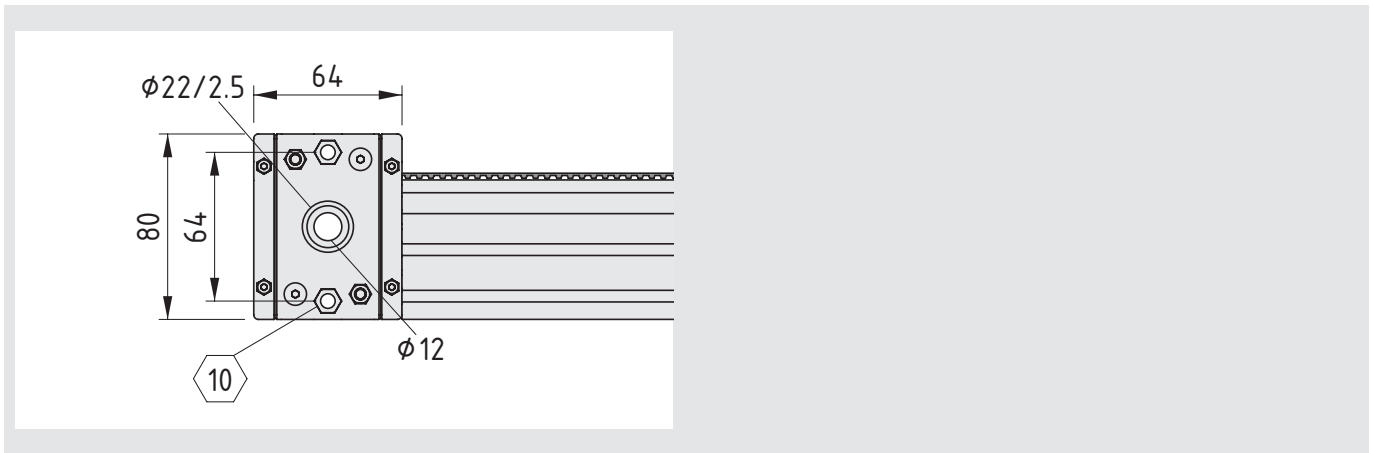

Installing the Timing Belt

It may be necessary to open Timing Belt Reverse Unit 5 40 R10 in order to insert the Timing Belt into it. To do this, remove all the screws.

Never use a screwdriver or similar tool to prise open the casing of Timing-Belt Reverse Unit 5 40 R10 at its joints, as you may unintentionally break off the belt cover.

Separate the two halves of the casing by gently tapping the hub of the timing pulley (use plastic punches). Once the casing is open, thread the Timing Belt through and then close Timing Belt Reverse Unit 5 40 R10 again.

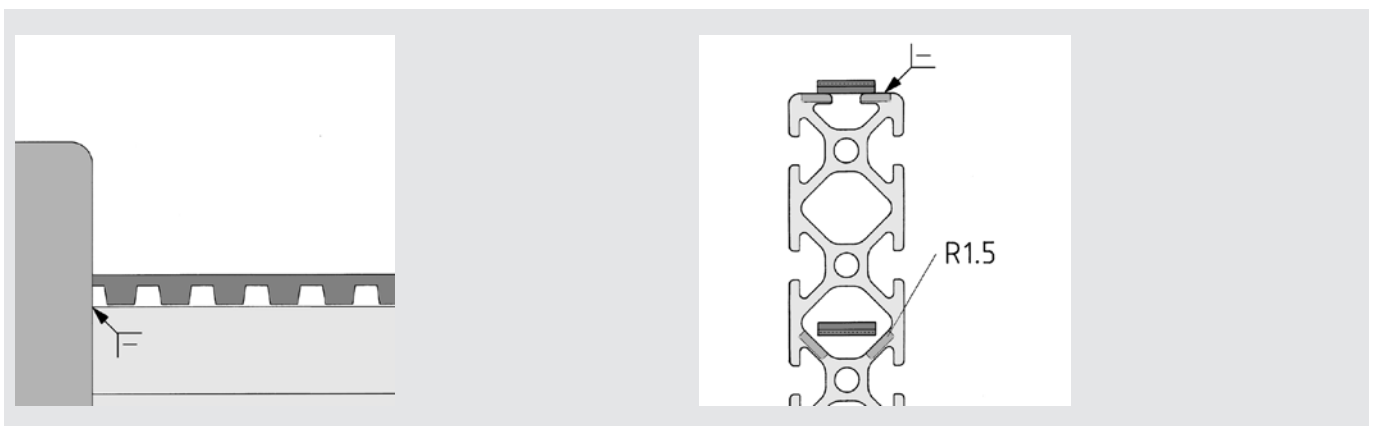

All the cut edges of the profile that face the Timing Belt must be chamfered to prevent irregular running caused by the belt getting snagged or damaged.

When feeding the Timing Belt back through the inside of profiles, ensure that the profile edges facing the back of the belt have been rounded.

Securing and tensioning Timing Belt R10 T5

To secure and tension the Timing Belt on a guide carriage, you will need to fit a Timing-Belt Tensioner Block in the correct width at each end of the Timing Belt.

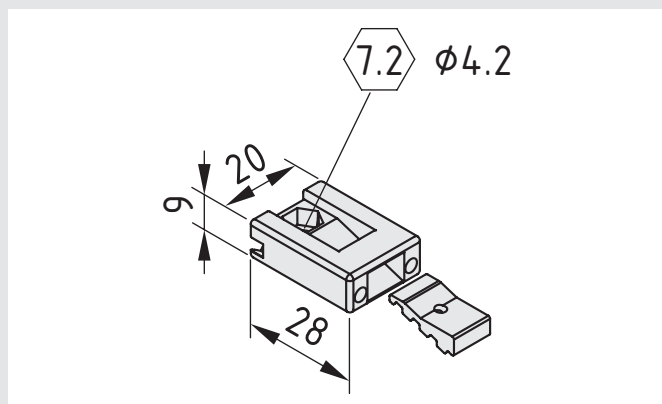
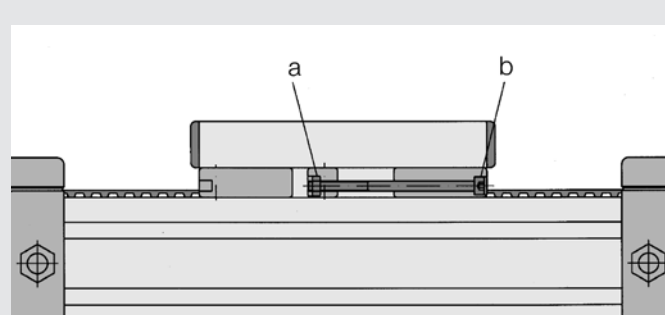

Timing-Belt Tensioner, Tensioning Block 5 R10, 0.0.400.07 [b]

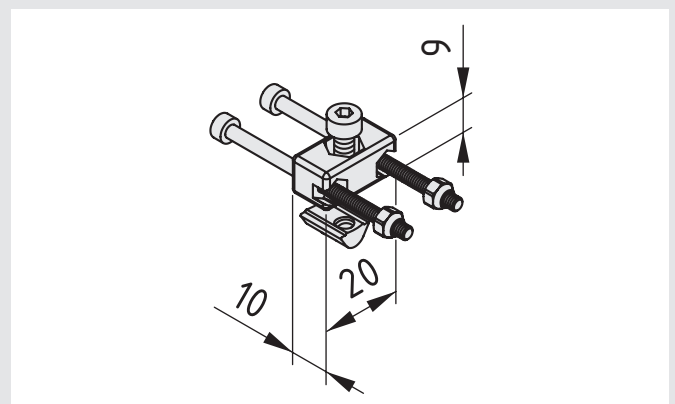

Timing-Belt Tensioner, Fixing Block 5 R10, 0.0.400.06 [a]

The corresponding holes, grooves and fastening materials are provided on the carriage for the purpose of fixing the tensioning elements in place. Insert both ends of the Timing Belt into the Tensioning Blocks so that the cavity inside each Tensioning Block is filled then screw securely into place. Fix one Tensioning

Block in place under the carriage plate and use the other to tension the Timing Belt with the aid of the long Hexagon Socket Head Cap Screws of the centrally located Fixing Block. When doing so, adjust the two tensioning screws alternately to ensure the tension on the Belt is evenly distributed.

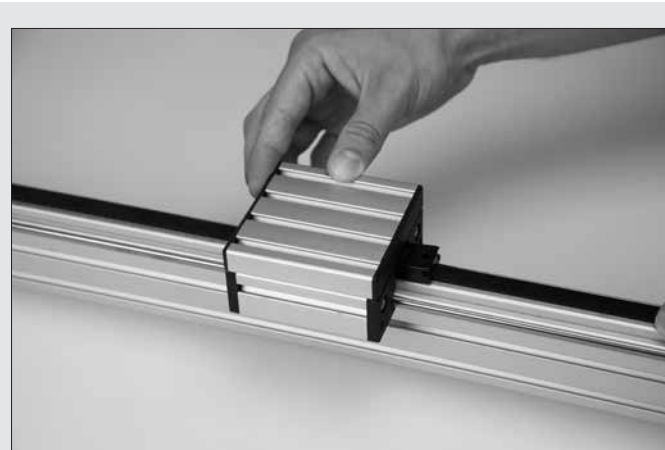

The necessary Timing-Belt tension must be determined and set in line with the anticipated loads.

⚠ If the Linear Unit LRE 5 D6 60x20 ZU 40 R10 has been supplied fully preassembled, you will need to check the pre-tensioning against the order specifications. After a running-in time of 24 hrs, check the operating tension of the Timing Belt again and adjust it if necessary.

When tensioning the Timing Belt, first identify the zero point at which the untightened Belt has no sag at all and pre-tensioning begins. To do that, draw the moving part of the Tensioning Block towards its fixed counterpart by alternately tightening the tensioning screws. Calculate the necessary tensioning adjustment or elongation of the Timing Belt according to the operating load of the Linear Unit.

Conventional calculation:

Following applies: $F_p + F_x < F_{Bperm}$

and: $F_p > F_x$

Where: $F_x = m \times a + m \times g + F_B$

Where: $\Delta L =$ Tensioning adjustment [mm]

$L =$ Total Timing Belt length [mm]

$F_p =$ Pre-tensioning force for Timing Belt [N]

$F_{Bperm} =$ Permissible force for Timing Belt [N] = 300 N

$F_x =$ Operating load [N]

$T_f =$ Frictional torque, loss of friction when running light [Nm] = 0.2 Nm

$r_E =$ Effective radius [mm] = 22.28 mm

$C =$ Constant of expansion [N] = 75 N

$$\Delta L = \frac{L \cdot F_v}{1000 \cdot K}$$

The calculated tensioning adjustment can be checked by various means. Typical tools include frequency analysis tools, strain gauges and simple length measuring devices.

Tip:

The necessary elongation calculated for the Timing Belt is constant along its full length.

The actual elongation of the Timing Belt as calculated for this segment can be checked and thus adjusted by marking a specific length on the Timing Belt (e.g. 1 m) and using a steel ruler.



Similar to the picture, which is purely an example to illustrate the measurement principle.

Accessories

The Proximity-Switch Fastening Set can be used to position and secure inductive Proximity Switches for homing positions and electric terminal position limits in the system groove of Timing-Belt Reverse Unit 5 40 R10. The Proximity

Switch fixings must be shortened as appropriate to the application scenario.

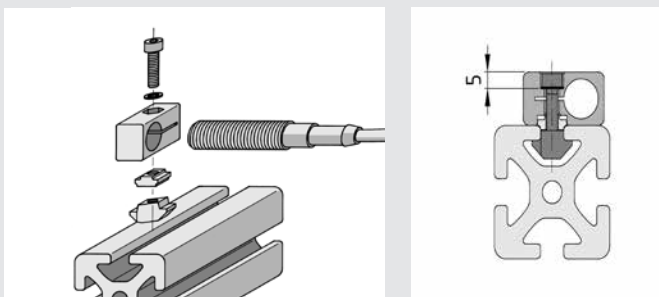

Limit-Switch Holders D6.5, D8 and D12 can be attached with anti-torsion blocks either parallel or at right-angles to the Profile 5 or Profile 8 groove.

Fasten Limit-Switch Holders D6.5, D8 and D12 in place with a Hexagon Socket Head Cap Screw DIN 912-M4, spring washer and T-Slot Nut for the corresponding Line.

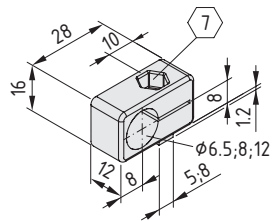

Limit-Switch Holder D6.5

Housing and anti-torsion block, PA-GF, black
 Spring washer, St, black
 m = 8.0 g

1 set 0.0.406.40

Limit-Switch Holder D8

Housing and anti-torsion block, PA-GF, black
 Spring washer, St, black
 m = 7.0 g

1 set 0.0.406.41

Limit-Switch Holder D12

Housing and anti-torsion block, PA-GF, black
 Spring washer, St, black
 m = 6.0 g

1 set 0.0.406.42

Connecting Drive Set 5 40 D30/D12 – 0.0.662.49

Drive Set 5 40 D30/D12 is used to connect any drive to Linear Unit LRE 5 D6 60x20 ZU 40 R10.

The expanding hub coupling fits the drive shaft and transmits drive torque without backlash.

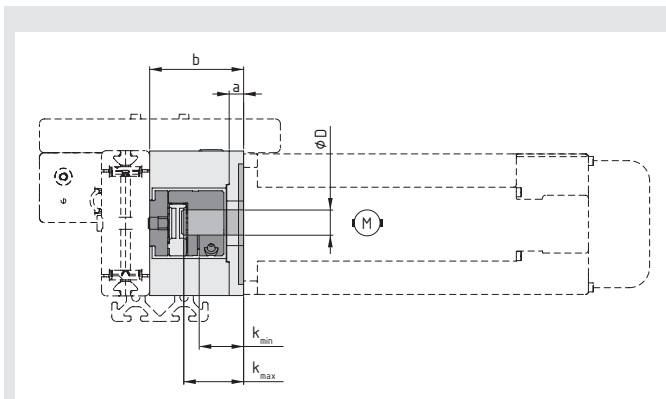

[mm]	5 40 D30/D12
Ø D	6-16
a	10
b	46
k _{min}	24
k _{max}	25.5

Hexagon Socket Head Cap Screws DIN 912 M6x25 are supplied with the Drive Set for this purpose and are screwed through the casing of the Drive Unit and into the Coupling Housing of the Drive Set.

Tightening torque: $T = 14 \text{ Nm}$

Machine the drive casing or Adapter Plate according to the requirements of the motor or gearbox you are using and then screw it to the motor or gearbox. Take the coupling half that is to be connected to the drive shaft and drill a hole in it to match the drive shaft then connect the coupling half and the shaft.

The torques transferred by the clamp connection factor in the maximum mating play for shaft fits: Shaft k6 / hole H7.

Force is transferred from the coupling to the drive shaft by means of frictional resistance. The Shaft and the hole in the coupling hub must be degreased and cleaned to ensure the frictional resistance is effective. Hexagon Socket Head Cap Screws must be secured against working loose.

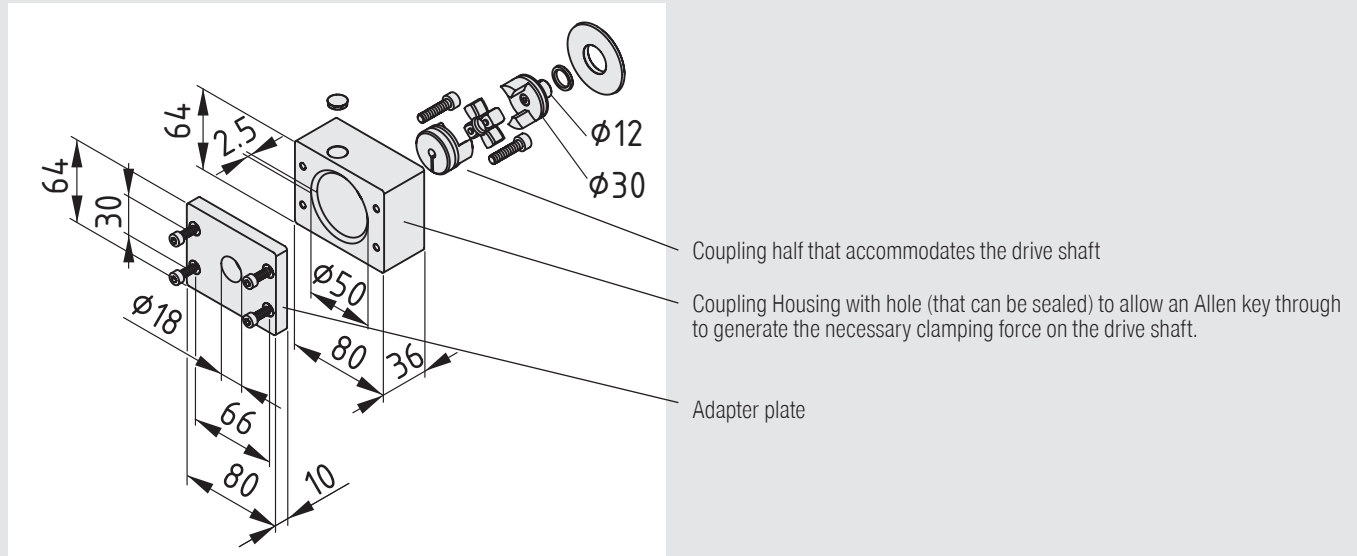

Connecting Drive Set ZU 5 40 D30/D12 AP/WP 40 – 0.0.672.74

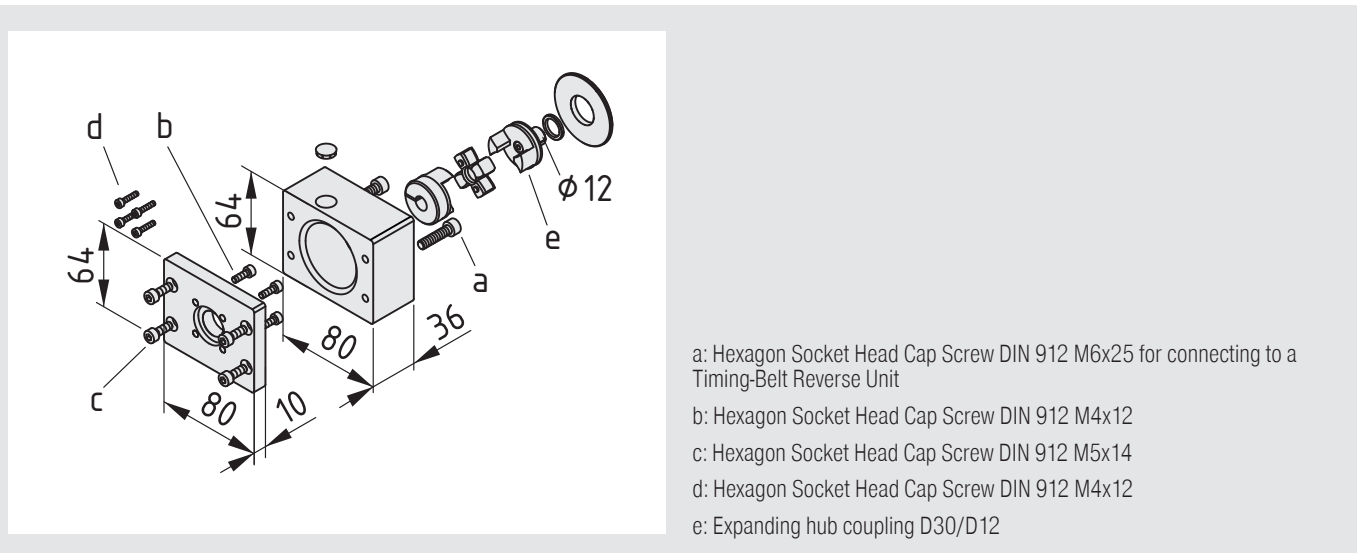

 The images below do not show the linear axis that is to be installed. However, the installation techniques and sequence are identical.

Drive Set ZU 5 40 D30/D12 AP/WP 40 – 0.0.672.74 is used solely to connect item drives. The Drive Set is fully prepared for installation on the corresponding

Linear Unit. The drive shaft transfers drive torque without backlash.

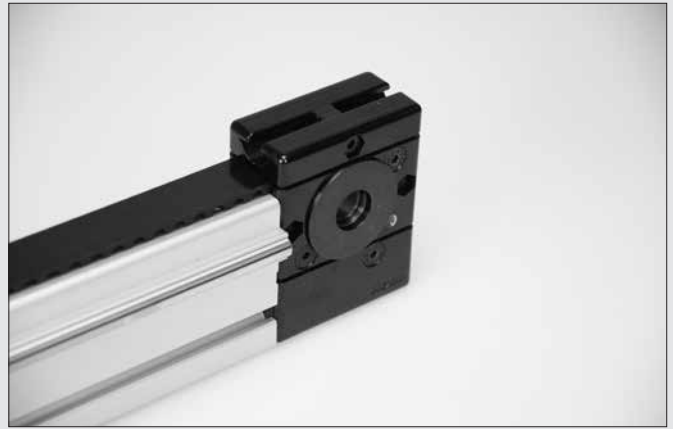

The torques transferred by the clamp connection factor in the maximum mating play for the shaft fits: Shaft k6 / hole H7. Force is transferred from the Coupling to the drive shaft by means of frictional resistance. The shaft and the hole in the hub must be degreased and cleaned to ensure a frictional connection for the drive. Fasten the first coupling half to the Reverse Unit, ensuring that the Hexagon Socket Head Cap Screws used are secured against working loose. Clamping screw: T = 2.8 Nm.

tion for the drive. Fasten the first coupling half to the Reverse Unit, ensuring that the Hexagon Socket Head Cap Screws used are secured against working loose. Clamping screw: T = 2.8 Nm.

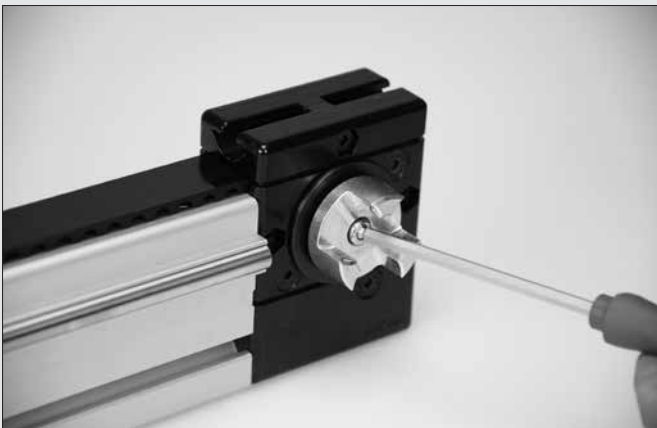

Use Hexagon Socket Head Cap Screws DIN 912 M6x25 (included with the Drive Set, T = 14 Nm) to screw the Coupling Housing of the Drive Set over the

entire Coupling through the casing of the Drive Unit.

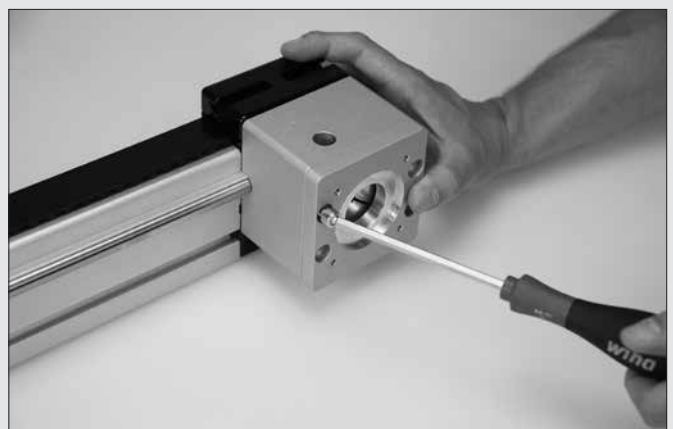
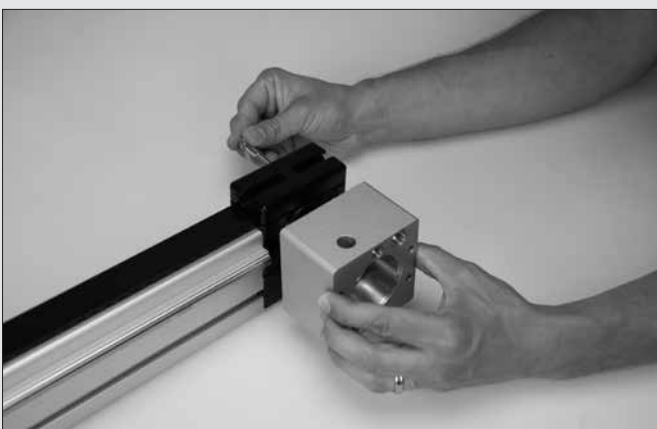

Next, use the prepared Centring Piece to fasten the Gearbox flush on the Adapter Plate of the Drive Set. Use Hexagon Socket Head Cap Screws DIN 912 M4x12 (T = 6 Nm) for this purpose. Next, screw the Adapter Plate to the Coupling Housing. Hexagon Socket Head Cap Screws DIN 912 M3x14 (T = 3 Nm) are included in

the Drive Set for the purpose of fastening the motor to the gearbox.

Working through the Coupling Housing, create a friction-based connection between the clamping hub screw (T = 2 Nm) of the clamp coupling half and the drive shaft.

Synchronising Linear Unit LRE 5 D6 60x20 ZU 40 R10

Synchronising Sets are used when two Linear Units are to be run in parallel. item Synchronising Sets comprise couplings that are fitted between two Linear Units and are connected by a Synchroniser Shaft that has been manufactured in the appropriate length. This ensures that the end result is a highly customised and flexible design.

Synchronising Sets from item can be used to operate two Linear Units in parallel with just one motor. They comprise shaft Couplings that are tailored to the relevant Linear Unit and designed to compensate for slight misalignments and withstand the stated torque over long-term use. The Couplings are pre-prepared

to accommodate a Synchroniser Shaft. Besides featuring a compact design, expanding hub couplings are also easy to use. The friction-based connection is created by tightening the central screw with the specified tightening torque. An integrated pull-off thread makes them easy to dismantle. First, the central screw is removed, then a longer screw is driven into the same position to effortlessly relieve tension in the Coupling. How long a Synchroniser Shaft can be depends on its operating speed. To determine the maximum length for a given speed or the maximum speed for a given length, please consult the information contained in the diagrams.

Linear Unit	Art. No.	Synchronising Set	Art. No.
Linear Unit LRE 5 D6 60x20 ZU 40 R10	0.0.666.89	Synchronising Set D30/D12	0.0.662.51

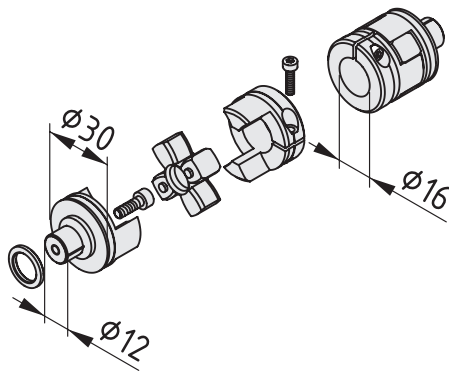

Synchronising Set D30/D12



- 2 Coupling Halves D30/D16, Al
- 2 expanding hub coupling halves D30/D12, St and Al
- 2 Coupling Inserts D30, PU, blue
- 2 Spacer Washers D12
- Tightening torque, expanding hub screw: 2.8 Nm
- Tightening torque, clamping hub screw: 2 Nm
- m = 93.0 g

1 set

0.0.662.51

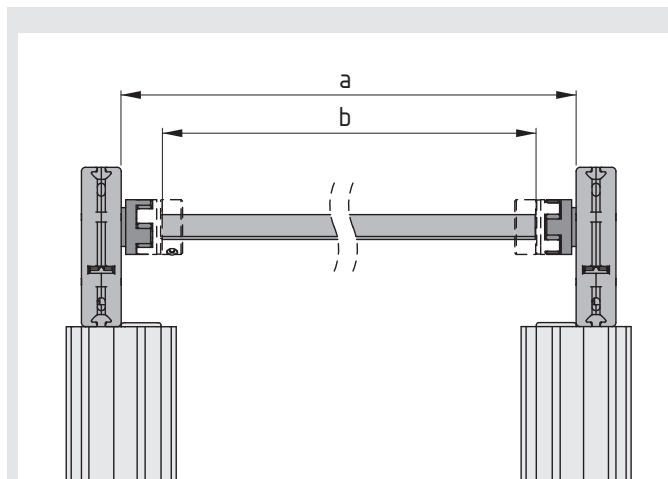

Similar to the picture

A suitable Tube St (sawn to length) turns the Synchronising Set into a complete Synchroniser Shaft.

Tube D16x1.5 St		
Synchronising Set	b	a
D30/D12	a - 42.5 mm	Distance between Linear Units

Lubrication

End Cap and Lubricating Systems are essential in order to protect and lubricate the Bearing Units. These should be fitted back in place only when the guide carriage has been mounted on the Shafts. Otherwise, it is important to ensure the movable wipers are pressed back when sliding the guide carriage onto the Shaft, to ensure they are not bent.

Wipers located in the internal recesses of the end-face End Cap and Lubricating Systems are also designed to take up the lubricant. They are pressed against the guiding Shaft by a spring. These wipers are supplied pre-charged with lubricant and can be topped up with lubricant as required via the hole in the cap.

In the event of considerable soiling, you may need to replace the wipers.

Maintenance

Suitable for use in dry conditions and over the temperature range -20°C to +70°C.

If operating conditions are unusual - e.g. special type of installation, dust, short stroke, influence of solvents etc. the lubrication intervals must be adapted accordingly.

This information does not discharge the user from the obligation to carry out his own assessments and checks.

It is important to bear in mind that our products are subject to a natural process of wear and ageing.

The rollers of the guide are maintenance-free. The spring-loaded end cap and lubricating felts can be topped up with lubricant as required via a hole.

Recommended re-oiling period: Every 6 months or every 2500 km. The felt pieces are supplied in ready-oiled condition.

Synthetic lubrication oil ISO VG 460, e.g. item Track Oil for Linear Guides (0.0.612.75).

Add the following quantity to each maintenance hole at the end of each maintenance interval: 1 ml

Greases containing solid particles (e.g. graphite and MoS₂ additives) must not be used!

Oil Can for Linear Guides (one actuation delivers approx. 1 ml of oil).

To ensure adequate lubrication, the carriage must cover a minimum travel distance. Minimum stroke length [mm]: 80 mm

The Timing Belt is a maintenance-free drive element.

Check the tension on the Timing Belt after a running-in phase.

We recommend regular checks for damage and wear. These checks should be carried out weekly at first and then adjusted to account for environmental and operational conditions.

The Timing Belt may need to be replaced.

Ideal operating conditions:

Ambient temperature: 10°C ... 40°C

Load: < 5%

item

item Industrietechnik GmbH
Friedenstrasse 107-109
42699 Solingen
Germany

Phone +49 212 6580 0
Fax +49 212 6580 310

info@item24.com
item24.com



You can find the Notes on Use and Installation online, in the download section for this product.